

GRAIN CLEANING EQUIPMENTS

ANAMILLING

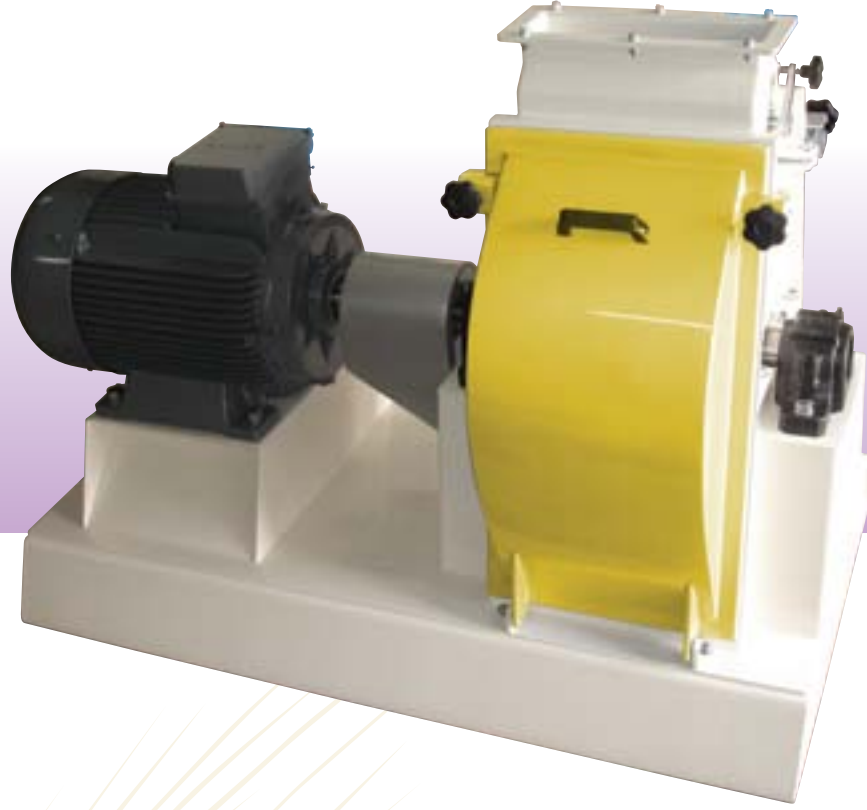

HAMMER MILL MODEL: ACHM

Çekiçli değirmen
Broyer á marteaux
Molino de martillos

HAMMER MILL - MODEL: ACHM



Hammer mills are used to grind screening, grain husk etc. The material is fed by a feeder. The grinding process is made between moving blades and perforated sleeve. The rotor consists of a steel shaft, hammers on the shaft. Rotor shaft is heat treated and felt holes are sand blasted. Hammers are strenghten abrasion proof with heat treatment. Doors for replacement for sieves designed for easy and fast replacement and maintenance.

Broyer á martillos sont utilisées pour broyer des projections, la cosse du grain, etc Le matériel est introduit dans la section d'admission par un chargeur. Le processus de rectification est fait entre les lames mobiles et le manchon perforé. Le rotor est composé d'un arbre en acier, des marteaux sur l'arbre.

Los Molinos de martillo se utilizan para moler y cribar las cáscaras del grano, y demás impurezas. El material ingresa en unidad de alimentación. El proceso de molienda se realiza entre las cuchillas en movimiento y la camisa perforada. El rotor está formado de un eje de acero y los martillos en el eje.

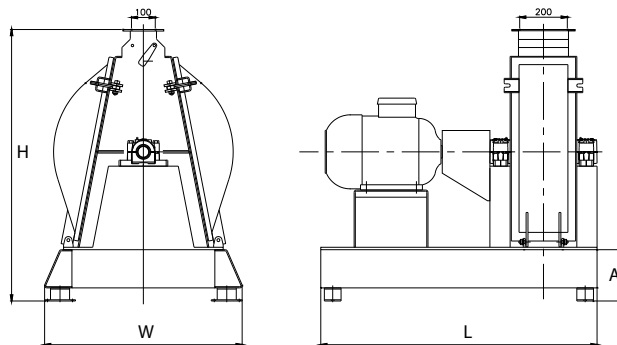

MODEL		ACHM-10	ACHM-25
Capacity	(t/h)	1 (by 11 kW)	2 (by 22 kW)
			2.5 (by 30 kW)
Dimension (mm)	A	215	215
	H	1138	1138
	W	830	830
	L	1160	1160

The indicated capacities are for screenings of flour mills and with 3 mm sieve, and may vary depending on the composition of the material and humidity.